

REVISE		VER.	A
ITEM	DESCRIPTION	DATE	

FINIALY

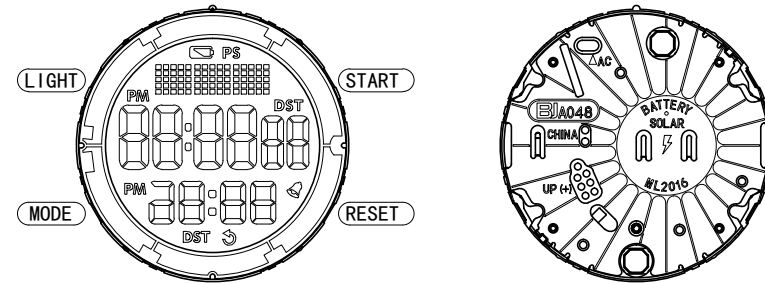
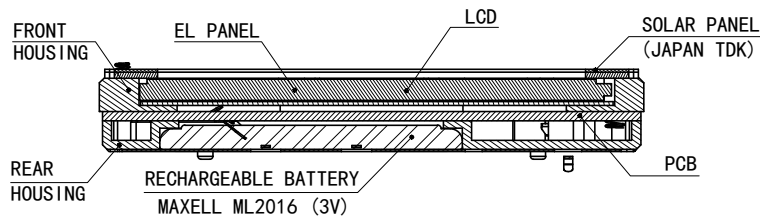
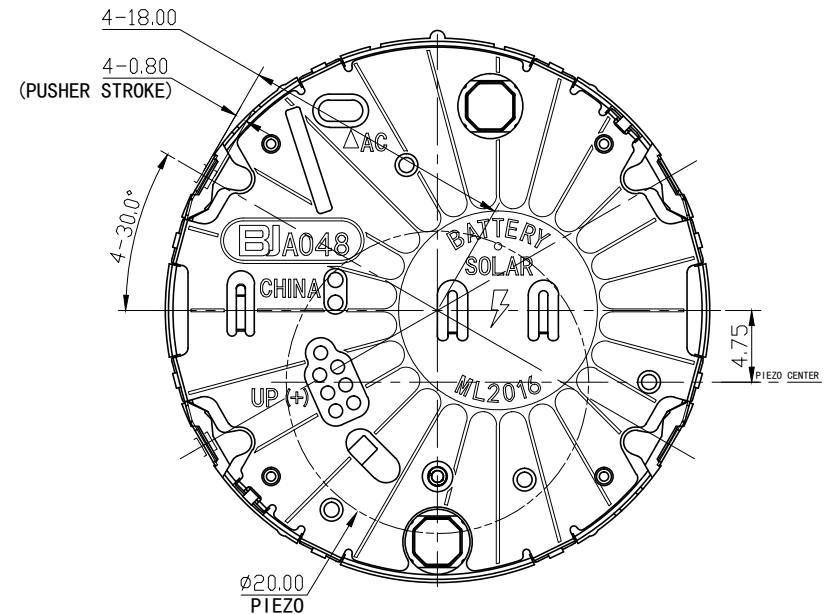
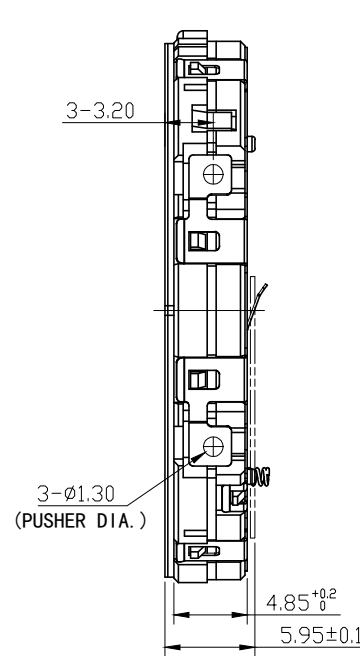
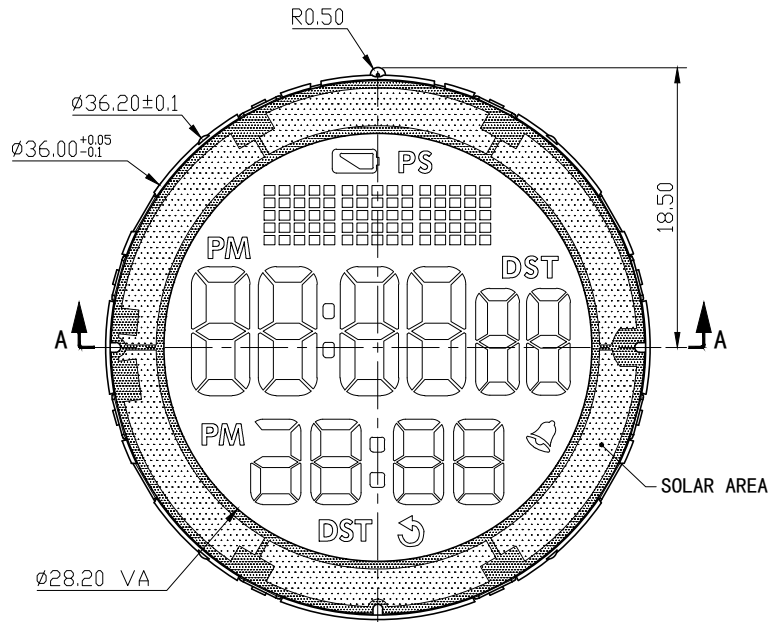

SCALE: 1:0.5:1

MODULE DESCRIPTION:

1. Module size (with dowels): $\phi 36.20 \pm 0.05$
2. Module size (without dowels): $\phi 36.00^{+0.05}_{-0.10}$
3. Module thickness (with buzzer/piezo): 5.95 ± 0.10
4. Recommended case size (without dial or inner ring): $\phi 36.15^{+0.05}_{-0.00} \times 6.05^{+0.05}_{-0.00}$
5. LCD type: FSTN

MODEL NO.	BJA048	DRAWN	CHECK	APPROVE	ANGLE
		L. P.	JOHNNY	BILLY	
TITLE	MODULE ASSEMBLY	2022. 11. 08	2022. 11. 08	2022. 11. 08	
STRUCTURE	NEW	PAGE 1 OF 1		SCALE: 2 : 1 : 1	
UNIT:	mm	BAO JIE ELECTRONICS (SHEN ZHEN) LIMITED 宝捷时计电子(深圳)有限公司			
TOLERANCE:	± 0.10				